

HIGH PERFORMANCE LINE

EXTREME[®] 300 SERIES MICROCOIL[®] GRILLE

Model EPG324C

MEASURE THE WIDTH AND HEIGHT OF THE OPENING

STAINLESS STEEL CURTAIN

DOOR SIZE AND AREA

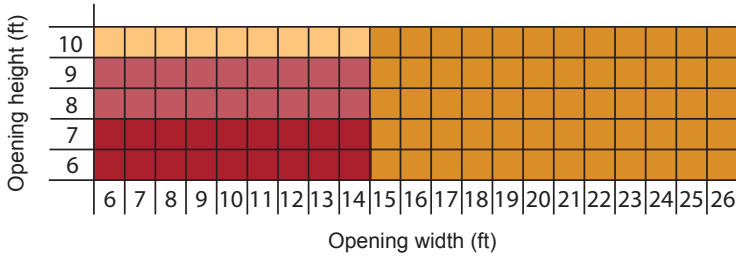

COMPONENT DIMENSIONS

	A	B	C	D	E
10.5"	12.4375	5.625"	12.75"	2"*	
10.75"	12.625				
11"	12.9375				
11.75"	13.6875				

*Dimension is 3" if a sensing edge is present

ALUMINUM CURTAIN

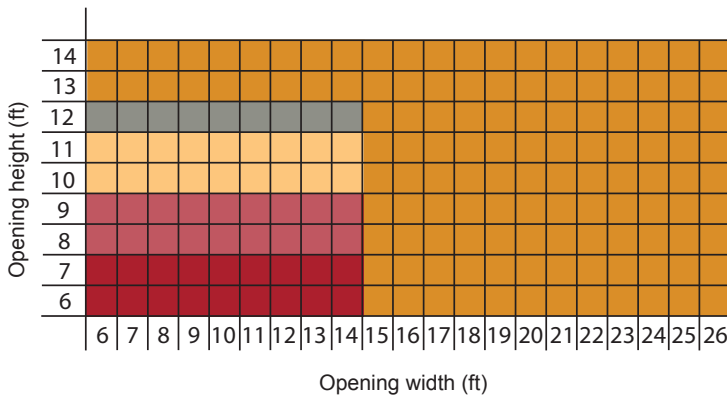

	A	B	C	D	E
10.5"	12.4375	6"	13.125"	2"*	
10.75"	12.625				
11"	12.9375				
11.375"	13.25				
11.75"	13.6875				

* Dimension is 3" if a sensing edge is present

CURTAIN DESIGNS Straight and Brick

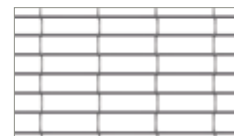

Straight

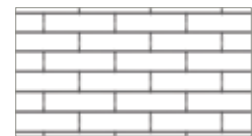

Brick

The dimensions featured on this sheet are provided as a rough guide for planning purposes. Exact dimensions cannot be provided until field conditions and all options are confirmed. Once field conditions are confirmed, please visit our website at www.cornelliron.com/drawings to generate custom drawings on demand for your specific opening.

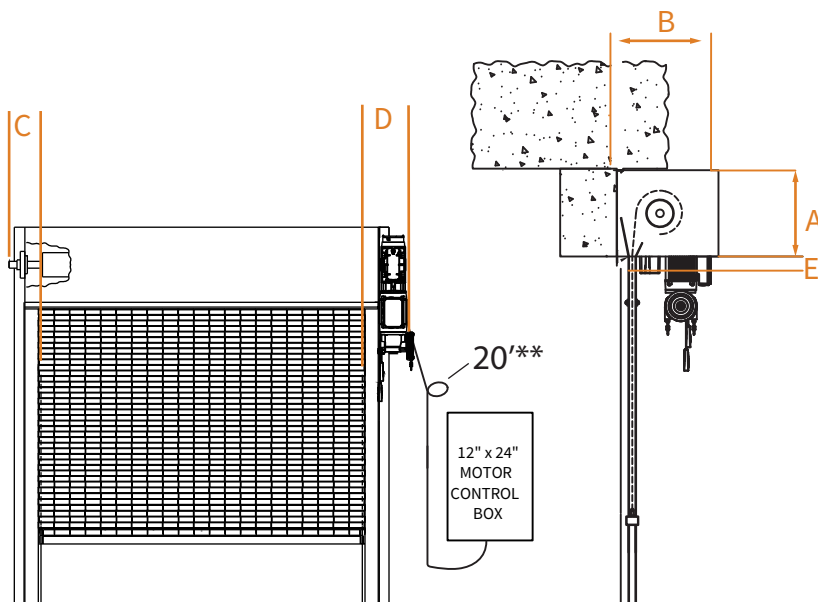

**Additional lengths are available, please contact the factory.

GUIDE CONSTRUCTION OPTIONS

STAINLESS STEEL CURTAIN

FACE OF WALL Z

Typically used with masonry wall construction, guides are mounted to the interior or exterior side of the wall.

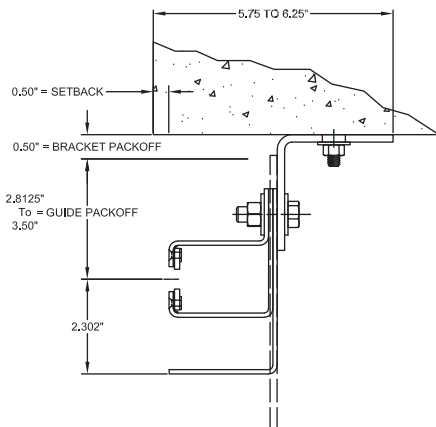

FACE OF WALL E

Typically used with steel jambs, guides are mounted to the interior or exterior side of the wall.

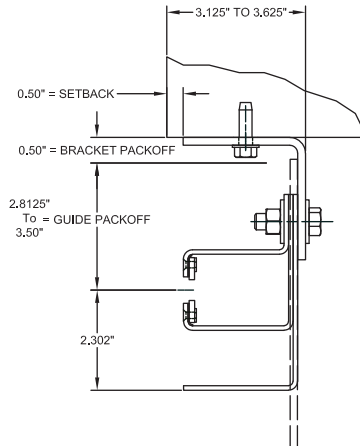

BOTTOM BAR

Compact stainless steel 300 series in #4 finish.

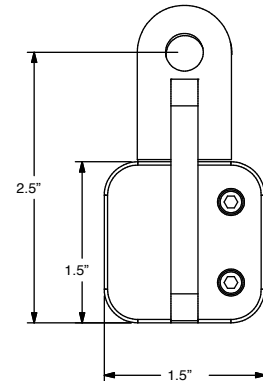

ALUMINUM CURTAIN

FACE OF WALL Z

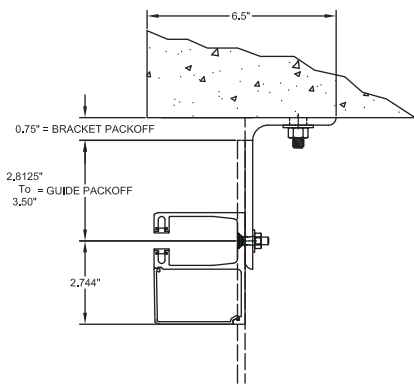

FACE OF WALL E

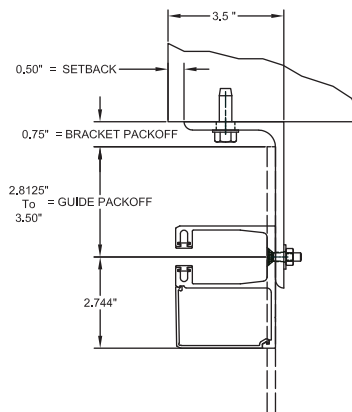

BOTTOM BAR

Compact extruded aluminum in mill finish.

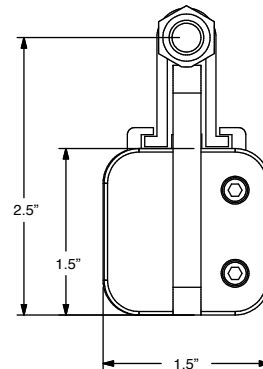

The dimensions featured on this sheet are provided as a rough guide for planning purposes. Exact dimensions cannot be provided until field conditions and all options are confirmed. Once field conditions are confirmed, please visit our website at www.cornelliron.com/drawings to generate custom drawings on demand for your specific opening.

CUSTOM-DESIGNED SOLUTIONS

Our experienced Architectural Design Support Team can customize our products to fit your specific application. Call 800.233.8366 ext. 4551 • architecturaldesignsupport@cornellcookson.com