

CORNELL
Innovative door solutions.™

EXTREME[®]
300 Series
Rolling Grille
Installation Instructions

Section 1 – Table of Contents





Section 2 – Safety Check List	2
Section 3 – Freight Receiving	3
Section 4 – Pre-installation	4
Section 5 – Guides	5
Face of Wall Units Mounting to Wall	5
Face of Wall and Between Jamb Units Mounting to Free-Standing Tubes	7
Between Jamb Units Mounting to Wall	11
Mixed Guides	12
Section 6 – Barrel and Brackets	13
Preparation	13
Hoisting and Installing Barrel Assembly	15
Section 7 – Motor Operator Installation	17
Pro-FDG Chain and Sprocket Operator	17
Direct Drive Operator	18
Section 7 – Motor Operator Installation	18
Section 8 – Curtain Installation	20
Section 9 – Sensor Mounting	21
Section 10 – Hood, Fascia, and Covers	25
Hood Support Installation	25
Hood and Fascia Installation	26
Hood Splice Cover	27
Cover Installation	28
Section 11 – Torque Specifications	29
Section 12 – Maintenance Schedule	30
Appendix A – Extreme® 300 Series Construction and Maintenance	33

Section 2 – Safety Check List

Rolling doors are large, movable objects. They move with the help of electric motors or manual operators (chain, crank, push up, etc), and most have springs under high tension. These items and their components can cause injury. In order to avoid injury to yourself and others, please follow the instructions in this manual.

- **Review the potential hazards and preventative measures listed below:**

Table 2.1 - Potential Hazards and Preventative Measures

Potential Hazard	Preventative Measure	
	<p style="text-align: center;">⚠ DANGER</p> <p style="text-align: center;">Pinned or crushed by closing door.</p>	<ul style="list-style-type: none"> • Keep yourself and others clear of opening while door is in motion. • Do not allow children to play near or operate door. • Do not operate if door becomes jammed or broken.
	<p style="text-align: center;">⚠ WARNING</p> <p style="text-align: center;">Struck by adjusting wheel bar while applying spring turns.</p>	<ul style="list-style-type: none"> • Be sure bar is adequate in strength and long enough to allow installer to apply the necessary torque. • Make sure bar is fully seated into the adjusting wheel slot before applying pressure. • Use two bars while applying turns to the adjusting wheel.
	<p style="text-align: center;">⚠ WARNING</p> <p style="text-align: center;">Electrical shock.</p>	<ul style="list-style-type: none"> • Make sure electrical operator is properly grounded. • Turn off source power completely prior to servicing the motor. • Make sure wires are clear of any moving or potentially moving parts. • Avoid pinching wires when installing the motor cover.
	<p style="text-align: center;">⚠ WARNING</p> <p style="text-align: center;">Pinched by moving components.</p>	<ul style="list-style-type: none"> • Make sure the motor is turned off and unplugged before working with moving parts such as roller chain and sprockets, drop-out mechanisms, adjusting wheels, etc. • Locate the possible pinch-points of the unit (Drive chain, coil area, bottom bar, etc.) Do not operate the door while someone is near these areas.

- **Check the following during installation and before leaving the job site:**
 - a. If the unit has tension springs, be sure the proper amount of tension is applied to the torsion springs, in order to properly counterbalance the weight of the curtain.
 - b. Securely fasten the tension adjusting wheel in place with the appropriate hardware provided.
 - c. Check that the keys and/or cotter pins have been set in place and fit properly at all sprockets or gears.
 - d. Check that the setscrews in each sprocket or gear (one over the key and one offset from the key) have been tightened properly.
 - e. Check all fasteners holding the unit to the building structures.
 - f. Check all fasteners used to assemble the components of the unit together.
 - g. Instruct owner or representative in the proper method of operating the door.

Section 3 – Freight Receiving

- **Upon delivery, check condition of components for damage.**
- **If damage occurred in transit, the installation should not proceed without authorization.**

NOTICE

If the installation proceeds, neither the carrier nor the manufacturer will assume responsibility for replacing the damaged material.

- **If the installation is stopped due to damage, do the following:**
 1. Take pictures of the damage.
 2. Do not move material from point of delivery to other premises once the damaged components are discovered.
 3. Do not unpack, if the damage is visible prior to removing packaging, until an inspection is made.
 4. If the damage is found while removing contents from packaging, the packaging material must be saved until inspection is made.
 5. Container and packaging should be retained by consignee until inspection is made.
 6. Have components inspected by carrier's representative within 15 days from date of delivery.
 7. Consignee must obtain a copy of the Inspection Report.
- **Returning damaged components:**
 1. Obtain permission from carrier to return.
 2. Route the return shipment via the identical carrier(s) involved in the original shipment.
 3. Notify the manufacturer when shipment is returned to manufacture plant.
- **Verify that all components have arrived. Look for the following:**
 1. Job construction drawings featuring different views (elevation, section, plan, etc.)
 2. (2) Guide assemblies; check for guide weathering if included in order
 3. Barrel assembly
 4. Curtain assembly with bottom bar attached
 5. (2) Bracket assemblies
 6. Operator; if not attached to bracket
 7. Operator cover; may not be included in order
 8. Adjusting wheel; if the barrel assembly contains springs
 9. Inertia brake; typically on units with springless barrel assemblies
 10. Hood and hood supports; may not be included in order
 11. Hardware
 12. Misc. items (Reelite, lintel seal, hood baffle, etc.)
 13. Verify material/finish/color of components matches what is listed on the job construction drawings and/or what was ordered.
- **If the delivery is incomplete:**
 1. Make note on delivery receipt.
 2. Note should be verified by driver's signature.
 3. Notify carrier and manufacturer.

Section 4 - Pre-installation

- **Read entire instruction manual thoroughly. The manufacturer will not be held responsible for any charges incurred due to improperly installed components.**
 - a. Only trained door systems technicians should perform installation, maintenance, etc.
 - b. Each unit comes with an individual item number. If the job contains multiple units, be sure to locate all the components for each item and separate each.

⚠WARNING

Do not interchange parts from one door to another.

- c. Find the job construction drawings for the unit being installed and check the dimensions of the opening against those on the drawings. See **Figure 4.1** below.
- d. If the opening dimensions differ from those on the drawings, **do not proceed**, check with distributor/manufacturer to be sure the correct door is being installed.
- e. Check the jambs of the opening for plumb. Check the head/lintel and floor for level. If the unit is to be free standing, for example mounted to tubes, check the floor and ceiling for level and for adequate mounting areas at the top and bottom.

Note: *The floor may not be level if a pitched bottom bar is specified.*

- **Work Area:**
 - a. The key to a smooth installation is a clean and well-prepared work environment. Once the components have been inspected and the job construction drawings have been reviewed; lay out the components in the order of installation.
 - b. The opening for the door should be cleaned and inspected for rough surfaces and construction debris.
 - c. Lastly the mounting hardware supplied with the door should correspond with the surface and construction features of the opening.
 - d. The basic assembly sequence is as follows: guides, barrel w/ rings or tapped holes, brackets, motor operator (if applicable), curtain, bellmouth, stoppers, weather stripping, hood, and operator/adjustor/idler covers.

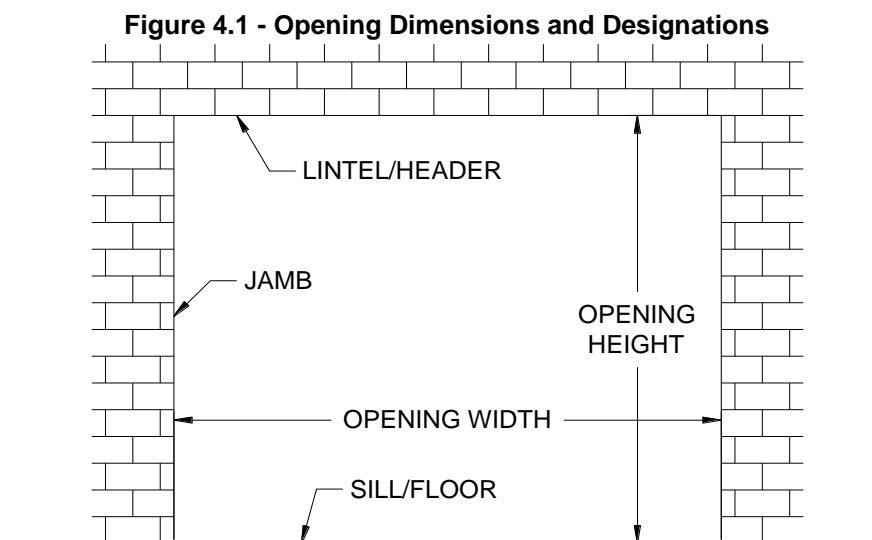

Section 5 – Guide Installation

- **Face of Wall Units Mounting to Existing Wall Construction (Figures 5.1 - 5.2):**

Note: Determine which guide assemblies are utilized on the unit from the job construction drawings and compare to the diagrams below.¹

Figure 5.1 – Face of Wall “E” Guide

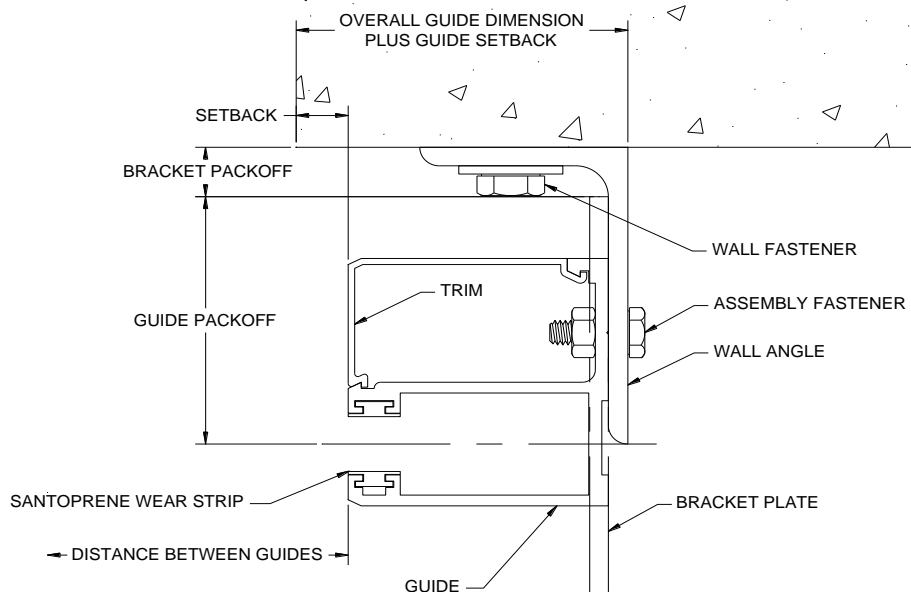
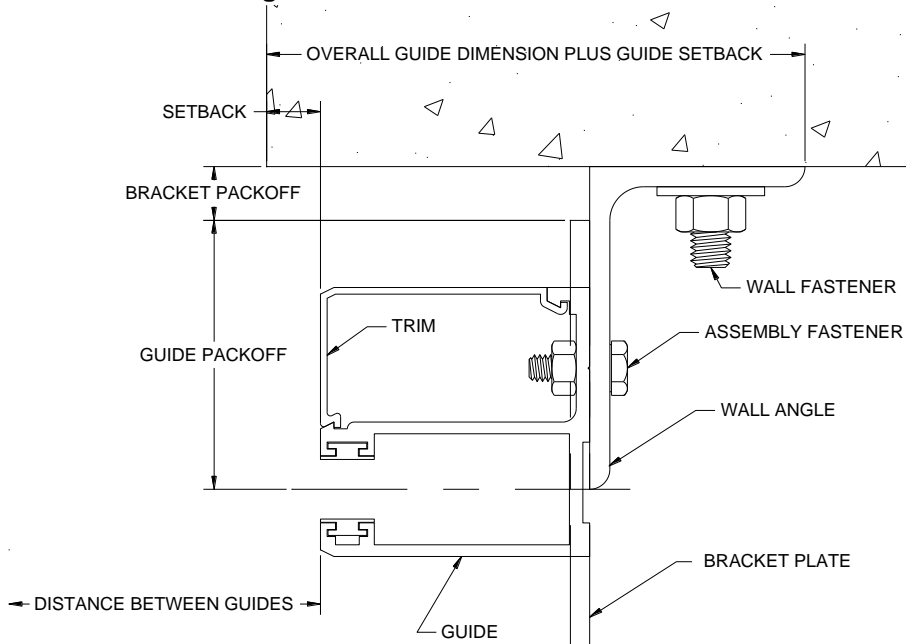

Figure 5.2 – Face of Wall “Z” Guide



¹ The guide assembly may differ from the right to left hand side of the unit. In these cases, follow the directions for each particular guide assembly, as well as the job construction drawings provided with the unit.

Section 5 – Guide Installation

1. Separate the trim and guide from the wall angle if necessary.
2. Measure the distance from the opening/jamb to the heel of the wall angle (on “E” guides) or the toe of the wall angle (on “Z” guides). This distance is referred to as the “*Overall Guide Dimension plus Guide Setback*”; see **Figures 5.1** and **5.2**. See the job construction drawings for the guide setback and overall guide dimensions.
3. Place mark on the floor at measured location. Check the distance between these marks and compare with the job construction drawing. It will be the “*Opening Width*” plus the “*Overall Guide Dimension plus Guide Setback*” at both jambs.

NOTICE

If the measurement does not equal the dimensions on the job construction drawings, **STOP**. Check the guide dimensions against those on the job construction drawings to be sure the correct guides are being installed. If so, repeat previous step and re-check.

4. Scribe a plumb line on the wall from the marks on the floor.
5. Place the wall angle against the scribed line, check the top of the guide for level, and mark the location of the wall fastener mounting holes.
6. If the wall angle is attached to the wall with fasteners, drill mounting holes for the wall fasteners and fasten the wall angle with the hardware provided. Check the job construction drawings for the required wall fastener. Tighten the wall fasteners to the recommended installation torque in the *Torque Specifications Tables* in **Section 10**.
7. If the wall angle is attached to the wall by welding to structural steel, see the job construction drawings for details on weld location, type, pitch, size, etc.²
8. At this point, the aluminum guide extrusion can be reassembled to the wall angle using the hardware provided. It is not necessary to snap the trim into place at this time. Tighten to the recommended installation torque in the *Torque Specifications tables* in **Section 10**.

Note: You may find that delaying the installation of the aluminum guide extrusions until after the curtain is installed may alleviate the curtain installation process. This is a matter of preference, and will not affect the final product. If this is the case, set the guide extrusions, trim pieces and hardware aside until after the curtain is installed.

² Minimum recommended weld rod: AWS A5.1, Grade E-70.

Section 5 – Guide Installation

- **Face of Wall and Between Jamb Units Mounting to Free-Standing Tubes (Figures 5.3 - 5.4):**

Note: Determine which guide assemblies are utilized on the unit from the job construction drawings and compare to the diagrams below.³

Figure 5.3 – Face of Wall “Z” Guide Mounting to Tube

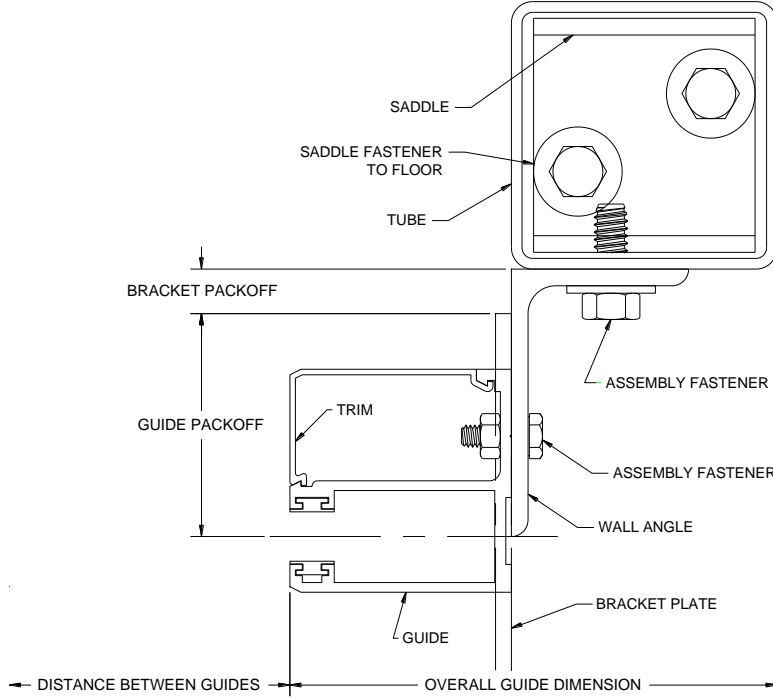
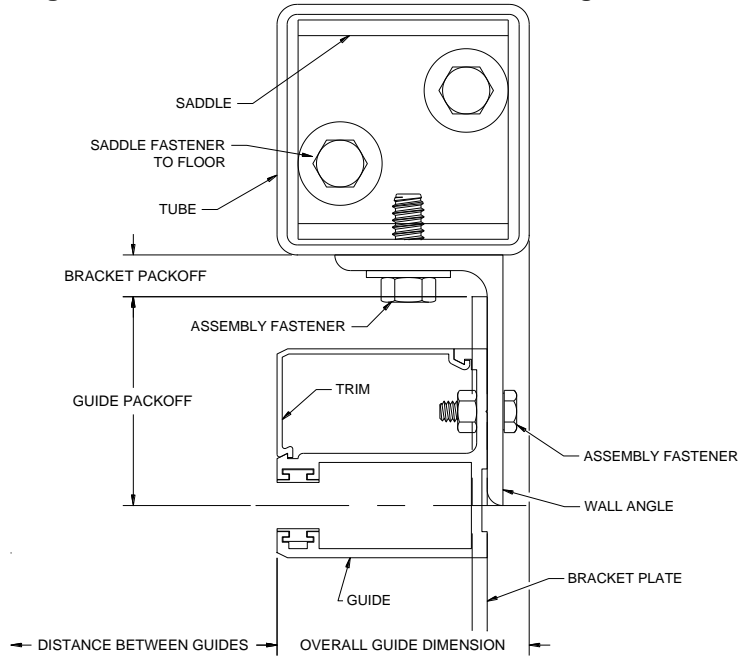

Figure 5.3 – Face of Wall “E” Guide Mounting to Tube



³ The guide assembly may differ from the right to left hand side of the unit. In these cases, follow the directions for each particular guide assembly, as well as the job construction drawings provided with the unit.

Section 5 – Guide Installation

Figure 5.5 – Between Jambs Mounting to Free Standing Tube

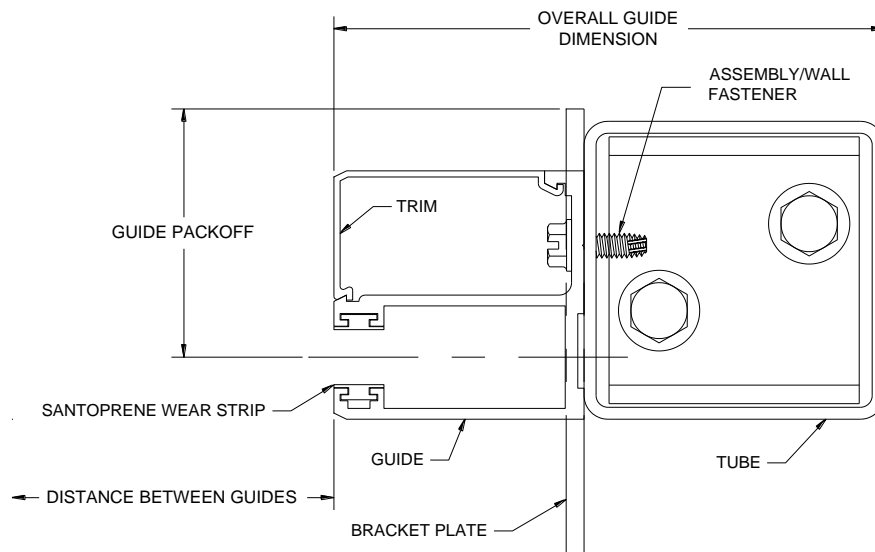

1. Separate the trim pieces, aluminum guide, structural tubes (and wall angles) if required.
2. Refer to the job construction drawings to determine the specified mounting tube location. Measure and mark the location of the mounting tubes.
3. Check the distance between these marks and compare with the job construction drawing. It will be the “*Opening Width*” plus the “*Overall Guide Dimension*” at both jambs.

NOTICE

If the measurement does not equal the dimensions on the job construction drawings, **STOP**. Check the guide dimensions against those on the job construction drawings to be sure the correct guides are being installed. If so, repeat previous step and re-check.

4. *Tube Saddles* are provided for installing free-standing tubes. Locate the tube saddles (brackets used to constrain the tube at the bottom). There are two types of saddles: *standard saddles* and *inverted saddles*. Both utilize the same steps for installation. The difference is the mounting flange.

Figure 5.6 – Tube Saddles

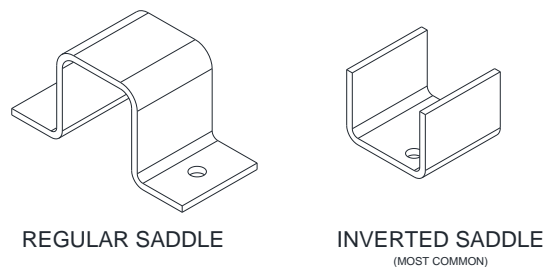
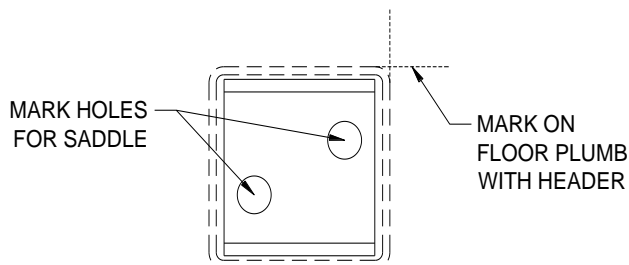

Figure 5.7 – Tube Saddle Hole Locations



5. Use the mark placed on the floor in the previous steps, to locate where the saddle will be and mark the hole locations by placing the saddle on the floor. See **Figure 5.7**.

Section 5 – Guide Installation

6. Double check the width dimensions provided on the job construction drawings, then drill holes for the saddle fasteners.
7. Install saddles using the provided hardware.
8. Guides mounting to tubes, sometimes require the use of a slip joint. Locate the Slip Joint Mounting Member(s).

Note: *If the unit does not have slip joints and the top mounting for the tube is not provided by the manufacturer, install as recommended by supplier, then proceed to **Step 13**.*

9. Use the job information and the marks made in the previous steps to determine the correct Slip Joint Mounting Member location. Install using the provided hardware. Use only enough fasteners to hold the Mounting Members securely in place (2), as they will be removed in a later step.
10. Determine the required tube length. Refer to **Figure 5.8**.
 - a. Measure from the “Floor to Slip Joint Mounting Member” as shown in the corresponding figure below. Record this measurement.
 - b. To allow for expansion, the steel tube will need to be cut short. To determine the required “Expansion Allowance”, round the measurement taken in the previous step **up** to the nearest foot increment. Multiply the rounded value by 1/8 in/ft. Refer to the table below for examples:

Table 5.1 – Slip Joint Expansion Allowances

Floor to slip joint mounting member (ft)	9	10	11	12	13	14	15	16	17	18	19	20
Expansion Allowance (in)	1 1/8	1 1/4	1 3/8	1 1/2	1 5/8	1 3/4	1 7/8	2	2 1/8	2 1/4	2 3/8	2 1/2

- c. Calculate the Tube Length:

$$\text{Tube Length} = \text{“Floor to Slip Joint Mounting Member”} - \text{“Expansion Allowance”}$$
- d. Cut the tubes to the calculated “Tube Length”. Make sure you cut the excess tubing from the top. Otherwise you will cut off necessary mounting holes and/or notches.

Note: *If regular saddles are provided, the tube length will have to be adjusted because the tube will not sit on the saddle flanges instead of the floor. Subtract the thickness of the flanges from the tube length.*

11. Remove the Slip Joint Mounting Member(s). Place the Slip Joint Mounting Members in the tops of the tubes.
12. Orient the tubes (ensure the guides, mounting holes or notches are facing the correct direction.) Place the bottom of the tube over the saddle. Stand the tube upright and reattach the slip joint mounting member using the previously drilled/marked holes to locate. Use all provided fasteners at this stage. Check that installed tube is plumb.

Figure 5.8 – Slip Joint – Between Floor and Ceiling Mount Assembly

Section 5 – Guide Installation

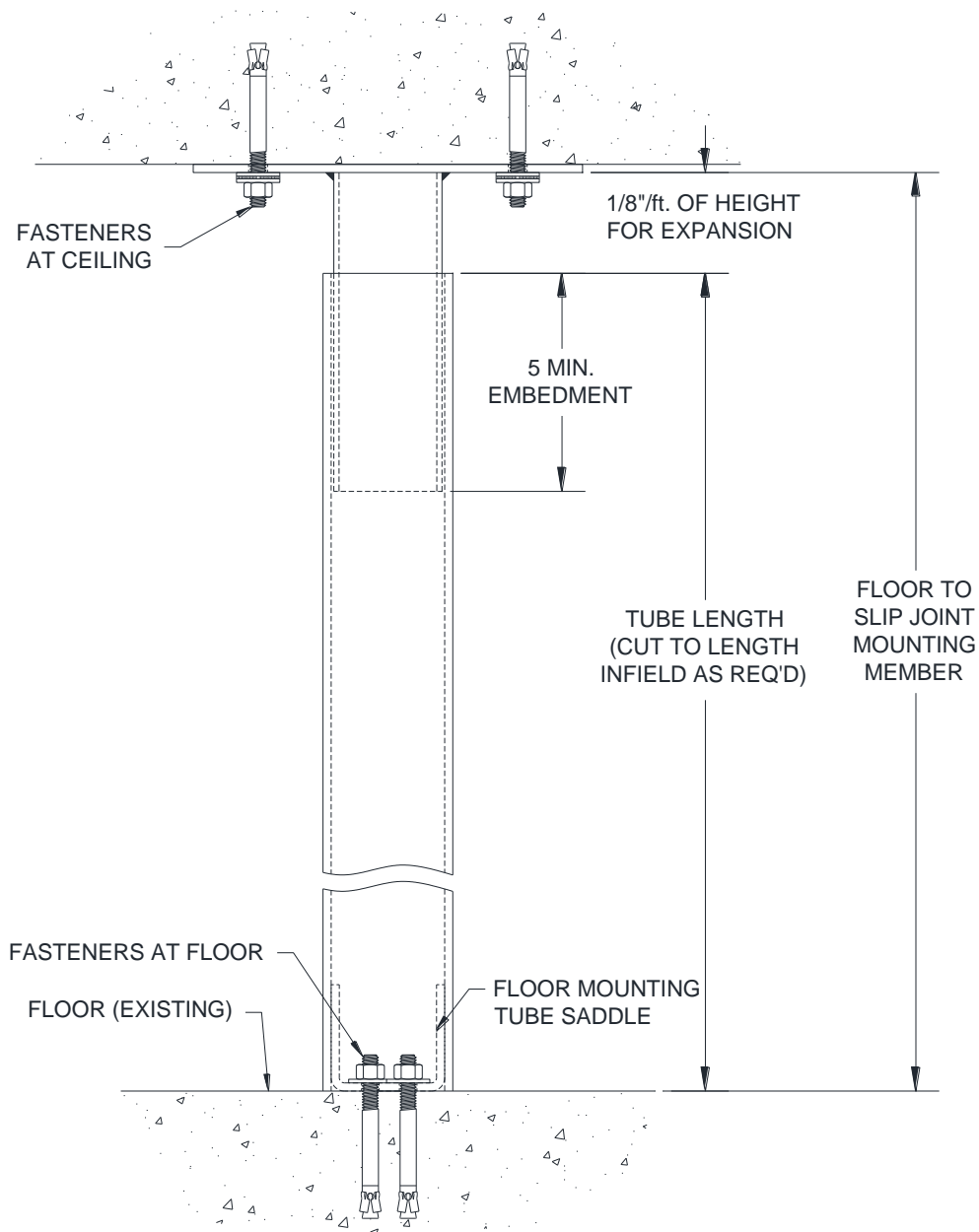

13. If the guide has a wall angle, as in **Figures 5.3 and 5.4**, fasten the wall angle to the mounting tube with the hardware provided. Check the job construction drawings for the required wall fastener. Tighten the wall fasteners to the recommended installation torque in the *Torque Specifications Tables* in **Section 10**.
14. At this point, the aluminum guide extrusion can be reassembled to the wall angle (or tube) using the hardware provided. It is not necessary to snap the trim into place at this time. Tighten to the recommended installation torque in the *Torque Specifications tables* in **Section 10**.

Note: You may find that delaying the installation of the aluminum guide extrusions until after the curtain is installed may alleviate the curtain installation process. This is a matter of preference, and will not affect the final product. If this is the case, set the guide extrusions, trim pieces and hardware aside until after the curtain is installed.

Section 5 – Guide Installation

- Between Jamb Units Mounting to Wall (Figures 5.9 - 5.10):

Figure 5.9 – Between Jambs with Back-Up Flat

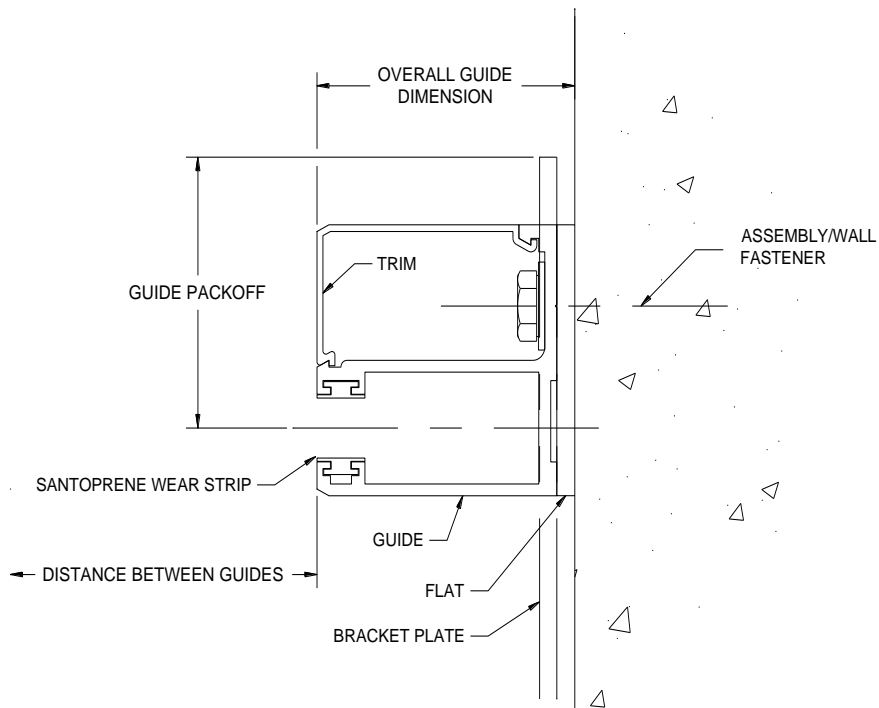
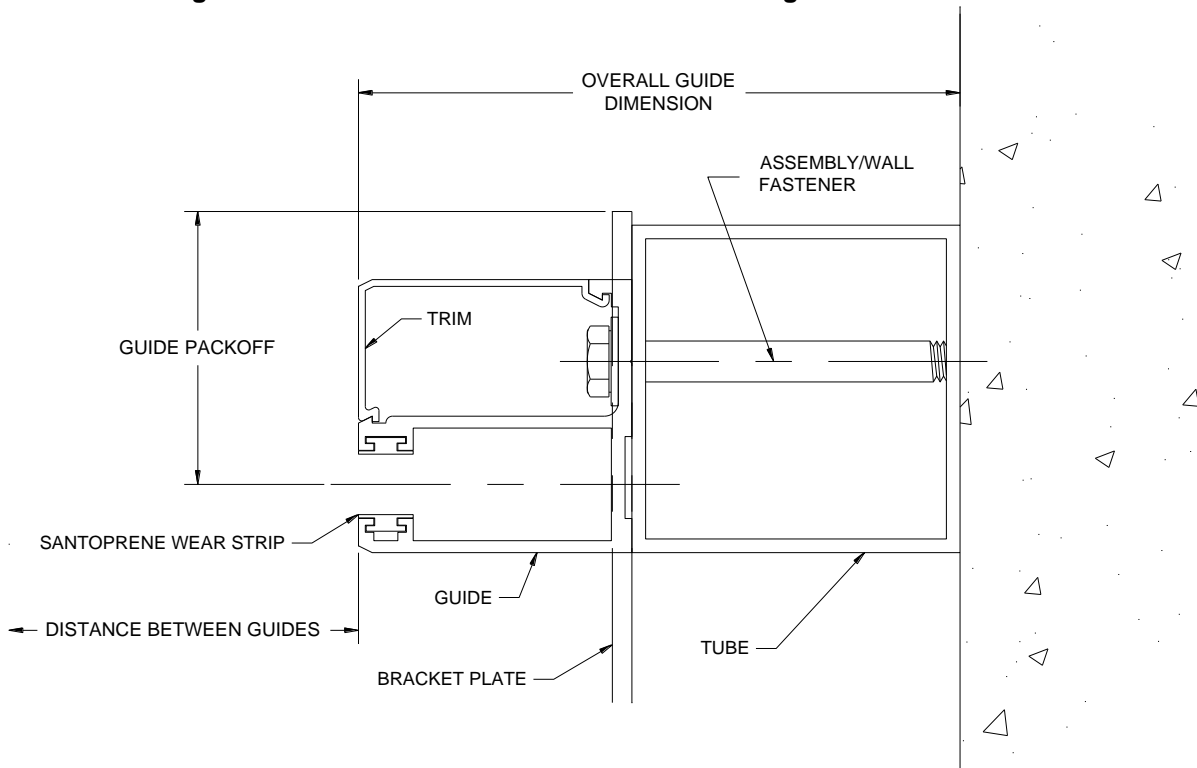

Figure 5.10 – Between Jambs with Tube Mounting to Wall



Section 5 – Guide Installation

1. Separate the trim pieces and aluminum guide extrusion from the flat or structural tubes if required.
2. Refer to the job construction drawings to determine the correct mounting location for the guide assemblies. Measure and mark the mounting locations on the floor.
3. Check the distance between these marks and compare with the job construction drawing. It will be the “*Opening Width*” plus the “*Overall Guide Dimension*” at both jambs.

NOTICE

If the measurement does not equal the dimensions on the job construction drawings, **STOP**. Check the guide dimensions against those on the job construction drawings to be sure the correct guides are being installed. If so, repeat previous step and re-check.

4. Using the markings made in the previous step, position the flat/tube in the correct mounting position. Making sure the flat/tube is plumb, mark the mounting hole locations on the jamb wall using the flat /tube as a template. It may be beneficial to also score a line along the edge(s) of the flat/tube in order to realign it later.
5. Remove the flat/tube and prep the mounting holes as required.
6. Align the mounting holes in the aluminum guide extrusion and flat/tube with the prepped holes in the jamb wall.
7. Fasten the guide extrusion and flat/tube to the wall with the hardware provided. Check the job construction drawings for the required wall fastener. Tighten the wall fasteners to the recommended installation torque in the *Torque Specifications Tables* in **Section 10**. It is not necessary to snap the trim into place at this time.

Note: Other mounting styles offer you the choice of waiting until after the curtain is installed to install the aluminum guide extrusions. This option is not available for Between Jamb Units Mounting to Wall.

- **Mixed Guides (One Face of Wall and One Between Jambs):**
 1. Refer to the job construction drawings for specific mounting information.
 2. Follow the steps in the preceding sections for each of the respective guide configurations.
 3. Ensure that the guide centers (centerline of the guide openings) are aligned before proceeding.

NOTICE

Once the guides are installed it is necessary to flare the upper portion of the guides where they meet the bell mouths. This will allow the curtain assembly to enter the guides smoothly without hanging up on the top of the guides. **Note: Failure to do this may result in damage if the curtain catches on the tops of the guide during operation.**

The tops can easily be flared by using a crescent wrench with the jaws set open just slightly wider than the thickness of the leg of the guide assembly. Slip the wrench over the leg of the guide slightly below the bell mouths and apply even, outward pressure until the top area of the guides flares outward past the bell mouths. This should be done to both legs of both guide assemblies.

Section 6 – Barrel and Brackets

Preparation of the Barrel and Brackets

Note: Check to see if a hood support will be required. If so, refer to the “**Hood Support Installation**” section before proceeding to the barrel and brackets.

1. Refer to the job construction drawings to determine the “coil side” of the opening, or the side of the opening on which the coil is to be installed. Then determine which jamb wall is your “operator side”, or side on which the operator is to be installed. The following instructions refer to these directional cues.
2. Unpack the barrel assembly. Note the markings on the barrel, see **Figure 6.1** below.

Figure 6.1 – Barrel Markings (right hand operation shown)

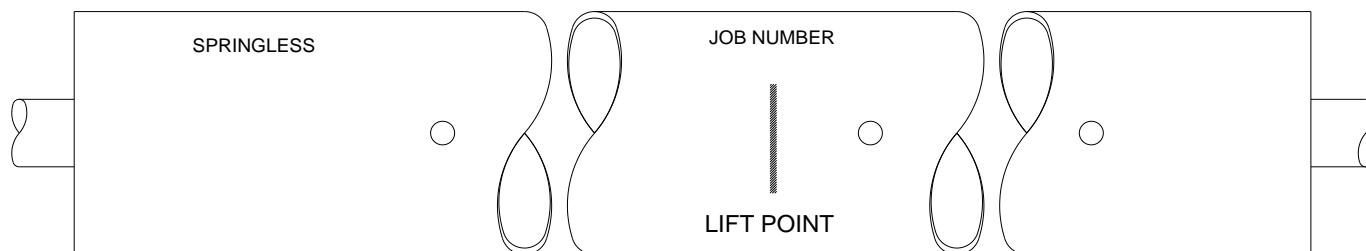

3. Position the barrel assembly on the coil side of the opening, with the end containing the longer gear end towards the “operator side” of the opening. In order to alleviate the bracket installation, place the barrel assembly on blocks or spacers such that it is elevated off the ground.

Note: Choose sufficiently sized blocks. The barrel assembly should be elevated off the ground enough that the brackets can be installed without contacting the floor.

4. Locate the brackets. Determine the “operator” and “idler” brackets by referring to **Figure 6.4**. The “operator” bracket may vary significantly based on the operation of the door. The “idler” bracket will come preassembled with an inertia brake.
5. Prior to installing brackets onto the shaft, install the provided spacers onto the shaft. See **Figure 6.2** below.

Figure 6.2 – “Idler” Bracket Attachment (right hand operation shown)

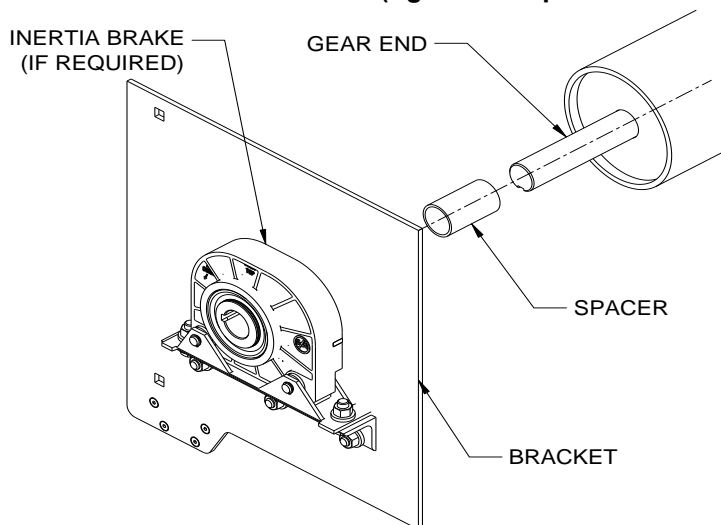

Section 6 – Barrel and Brackets

6. Remove the inertia brake (if required) from the idler bracket and set to the side.
7. Slide the idler bracket over the gear end until the bearing and the shaft are touching the spacer.
8. Reinstall the inertia brake (if required) placing the gib key on the gear end in between the inertia brake and the bearing. See **Figure 6.3** below.

Figure 6.3 – Idler Bracket Installation

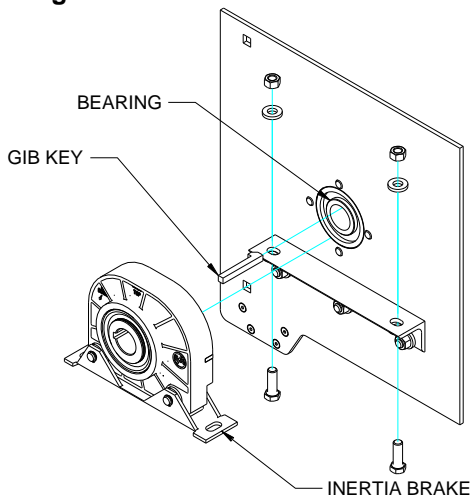

9. Slide the operator bracket over the gear end until the bearing and shaft are touching the spacer. Do not tighten the set screws at this point, as you may need to adjust the position of the bracket. You may choose to install the drive sprocket (if required) at this point.
10. If using and installing the Direct Drive operator prior to lifting the barrel and brackets into place, ensure that the “lift point” is adjusted to account for the additional weight of the operator at one end of the shaft. The alignment of the brackets to the wall angles may be easier if the operator is not secured to the bracket, but instead is just placed on the gear end.

Note: *If using the Pro-FDG chain and sprocket operator, it is recommended to not install the operator until the barrel and bracket assembly is hoisted into position and securely fastened to the guides. Installing this operator at this stage will cause the assembly to be lopsided and cumbersome, making it difficult and potentially dangerous to hoist into position.*

Section 6 – Barrel and Brackets

Figure 6.4 – Brackets and Barrel Prior to Installation

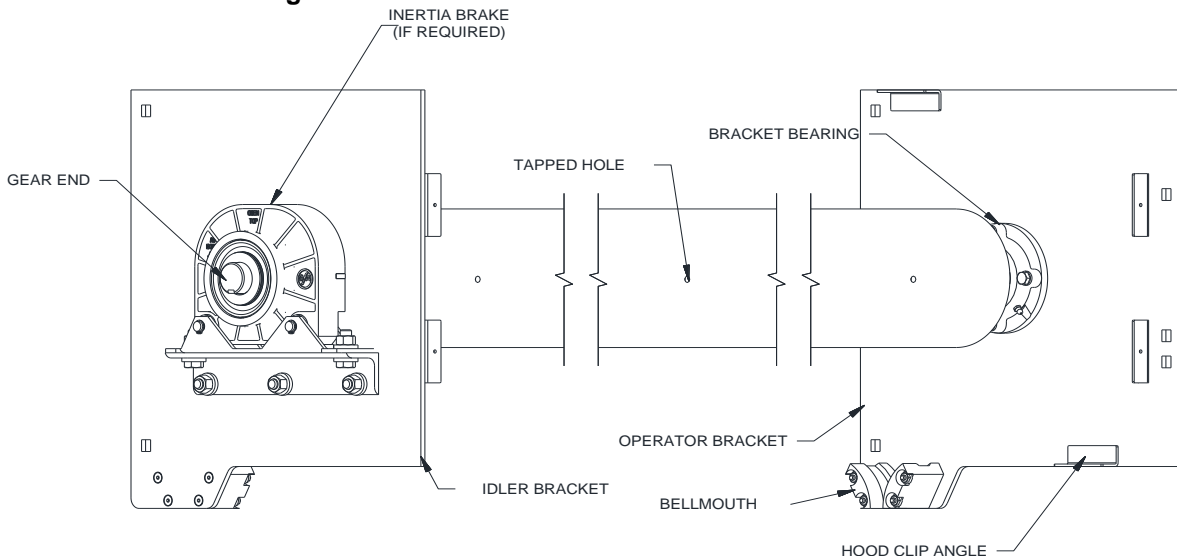

▪ Hoisting and Installing Barrel Assembly

1. The following methods can be used for hoisting them into place:
 - **Crane Hoisting:** Place a sling or lifting agent under the barrel assembly at the “lift point” provided on the barrel, see **Figure 6.1**.
 - **Forklift Hoisting:** Space the forks evenly under the “lift point” provided on the barrel, see **Figure 6.1**. Ensure that the barrel assembly is positioned close enough to the tips of the forks that the fastening holes in the bracket can be aligned with those of the guides without the forks contacting the wall. Secure the barrel assembly to avoid the slipping off the tip of the forks.

⚠ WARNING

The addition of brackets (and operator) may offset the balance slightly from when the “lift point” was marked. Check to make sure the assembly is properly balanced before hoisting.

2. Before hoisting, refer to the hardware sheet and ensure that the proper type and quantity of fasteners were provided for the bracket installation. Measure the distance between the brackets and compare that to your wall angles (*or between mounting angles if tubes are present*). Readjust the brackets as needed before hoisting.
3. Center the barrel assembly between the guides, keeping approximately 2 feet of clearance between the barrel assembly and wall/guides.
4. Raise the barrel assembly up to the approximate bracket mounting level. The brackets should be clear of the guide extrusion (if installed).

Note: Position the brackets in the upright position, with the mounting holes facing the wall, before moving the assembly towards the wall. It may be difficult to rotate the bracket when in close to the wall.

5. Slowly maneuver the barrel assembly towards the guide, and align the mounting holes of the brackets with those of the wall angles (*or mounting angles if tubes are present*).
6. Insert the specified bolts and snug tighten, see **Figure 6.5**.

Section 6 – Barrel and Brackets

Figure 6.5 – Bracket Mounting Configurations and Hardware

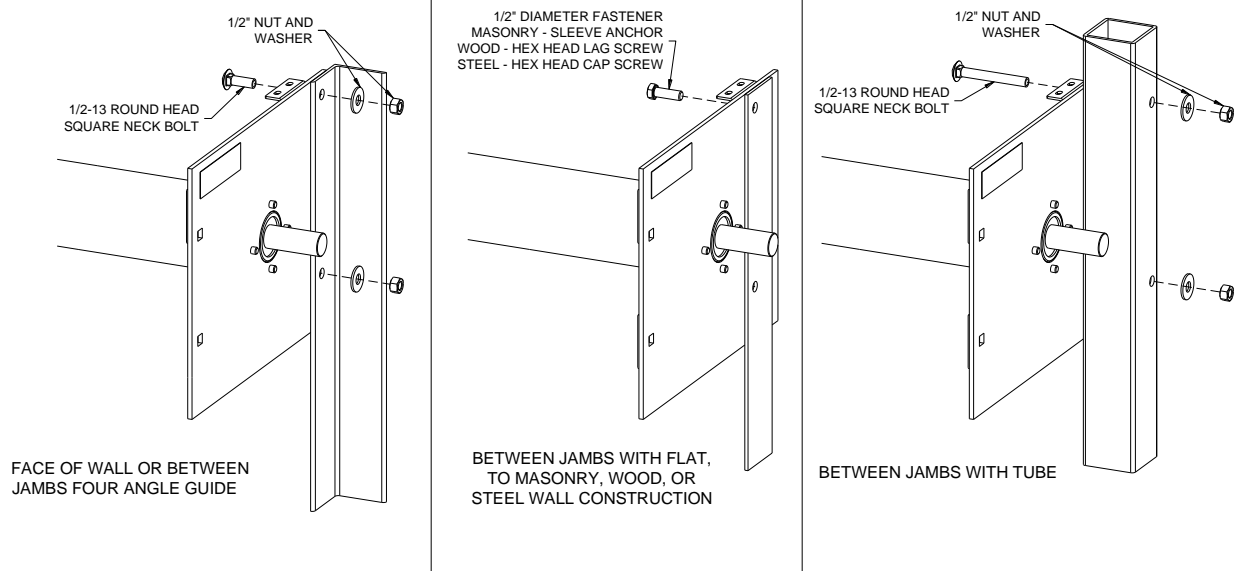

7. Check to see that the barrel is positioned properly between the brackets. That is, so that the proper amount of space is allowed between the barrel and the brackets. Typically the space is equal at both the operator and adjuster side. Adjust as necessary.
8. Place a level in the center of the barrel. If the shaft is **not** level:
 - Check the dimensions of the brackets from the top of the bracket to the center of the barrel.
 - Verify that the bracket mounting fasteners are the same distance from the top of the bracket.
 - a. If the dimensions **are not** correct, contact the Service Department.
 - b. If the dimensions **are** correct, the floor may be out of level, causing the bracket mounting holes in the guides to be out of alignment.
9. Fully tighten mounting bolts to the torque specifications in this manual. See *Torque Specification Tables* in **Section 10**.

NOTICE

Proper pretension of the bracket mounting bolts will benefit the life of the bolts and brackets.

Section 7 – Motor Operator Installation

Pro-FDG Chain and Sprocket Operator

▪ Motor Operator Installation :

1. Unpack the motor operator from the shipping box and retrieve the *Operator Mounting Bracket* and bolts provided.
2. Mount the operator mounting bracket(s) to the operator using the supplied fasteners. **Note:** *If a motor cover is required refer to ES10-354 prior to attaching the operator and operator mounting bracket.*
3. Mount the operator-mounting bracket(s) to the operator bracket according **Figure 7.1** or **Figure 7.2**, depending on the operator size, using the supplied fasteners.
4. Install controls and wire the operator. Refer to the wiring diagram provided with the operator for proper connections and voltages. The controls should be installed in an area from which the door/opening is clearly visible. This will allow an individual operating the unit to make a visual inspection of the opening for any obstacles or other potential hazards before setting the door into motion.

Note: *Do not attempt to set the upper and lower limits until the curtain is installed.*

▪ Attaching Additional Bracing :

1. Attach a clip angle to the operator mounting bracket and the bracing angle to the clip angle. Snug all bolts.
2. Mount the other supplied clip angle to the bracing angle and swing the bracing angle to the wall or structural support.
3. Align the mounting face of the clip angle with the face of the wall, mark and drill a mounting hole for the size of the supplied mounting fastener, and secure the clip angle to the wall with the fastener.
4. Square the operator-mounting bracket, adjusting the bracing angle as necessary, and fully tighten all the mounting bolts.
5. After attaching the bracing angle, use the provided horse-shoe shims to space out the operator and properly tension the drive chain.

Note: *All mounting bolts are supplied with nylon-insert lock nuts and washers.*

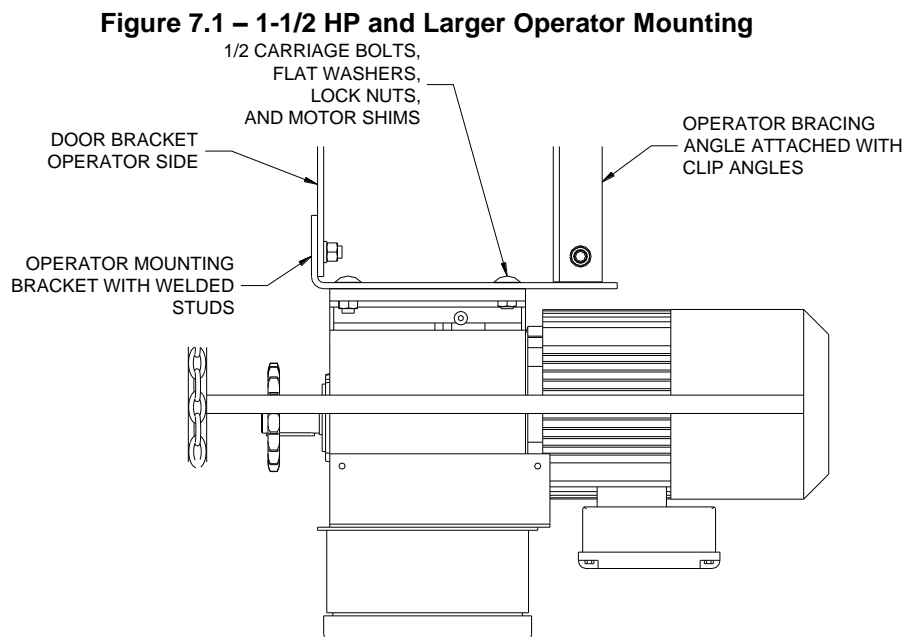

Section 7 – Motor Operator Installation

Figure 7.2 – 1 HP Operator Mounting

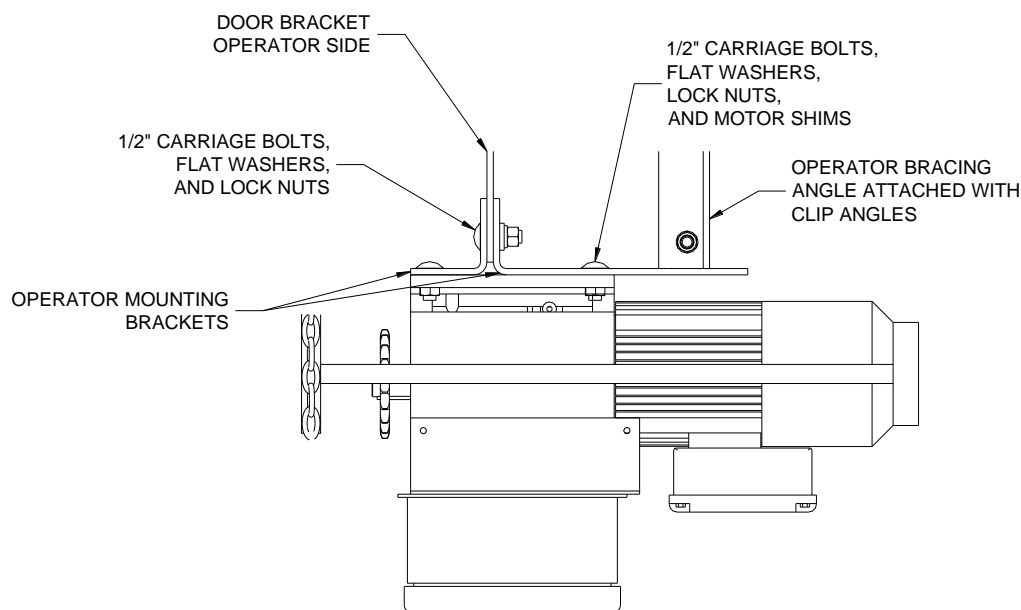

Direct Drive Operator

1. Unpack the motor operator from the shipping box and retrieve the mounting plates and hardware provided.
2. Refer to the shop drawings in order to understand the operator mounting configuration. See **Figure 7.3** for a vertical mount configuration or **Figure 7.4** for a horizontal mount configuration.
3. Attach the gearbox mounting plate to the operator using the provided hardware. Do not tighten the bolts at this time.
4. Attach the operator mount to the head plate. Do not tighten the bolts at this time.
5. In the unlikely event of the operator needing to be removed for maintenance in the future, anti seize lubricant has been provided. Prior to installation apply the anti seize lubricant to the gear end, Gib key, and inside hub of the operator.
6. Place the Gib key in the keyway of the gear end. Slide the operator over the gear end of Gib key, ensuring the keyways are aligned. The keyways can be aligned by rotating the barrel by hand or utilizing the auxiliary hand chain on the operator.
7. Attach the gearbox mounting plate to the operator mount using the provided vibration isolators and hardware.
8. Align the operator and mounting plates so that the operator hangs freely on the gear end.
9. Tighten all the bolts at this time.
10. Remove the bolt in the front/top of the gearbox housing and install the provided vent plug.

NOTICE

Installation of the vent plug is critical to safe operation of the operator. Failure to install the vent plug may cause permanent damage to the operator.

Section 7 – Motor Operator Installation

Figure 7.3 – Vertical Motor Mount

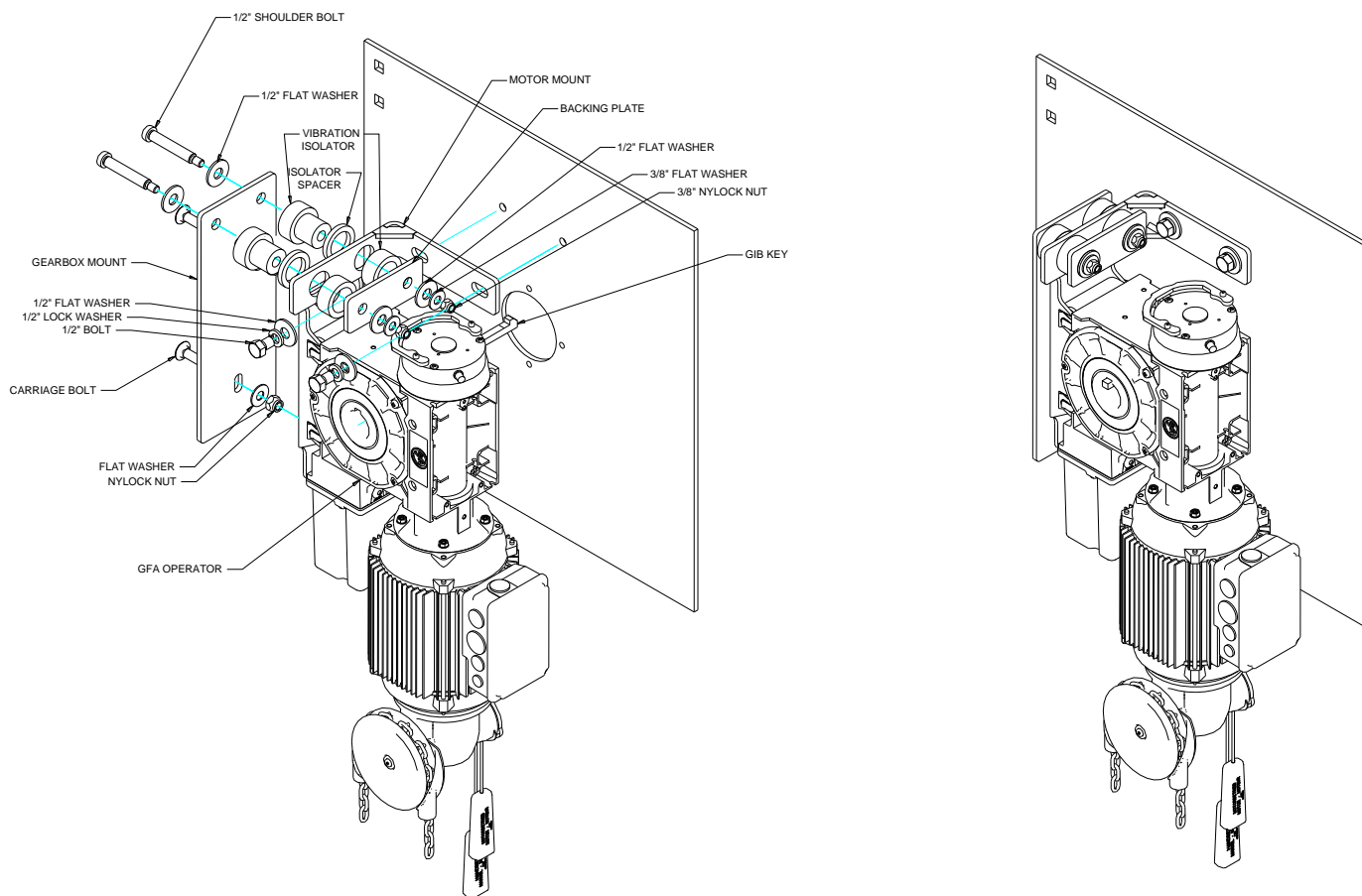
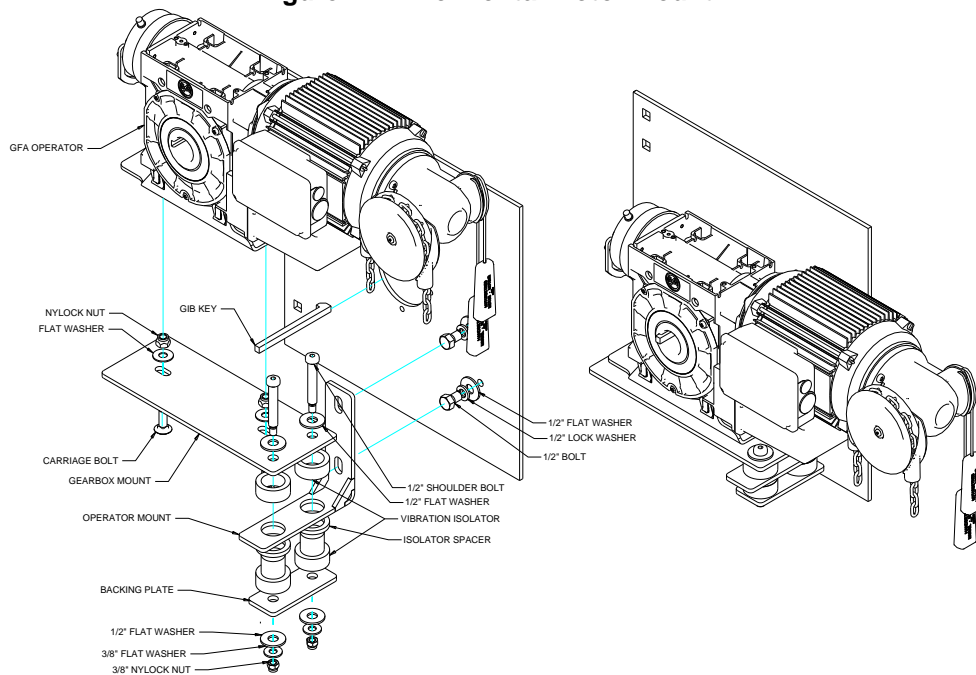

Figure 7.4 – Horizontal Motor Mount



Section 8 – Curtain Installation

▪ Curtain Installation

1. The guides are usually shipped with the stoppers positioned so they will not interfere with the bottom bar to alleviate the installation process. Check to make sure the stoppers are positioned correctly for installation (whether they are installed at this point or not.)
2. Open the curtain packaging. Leave the plastic straps that keep the curtain from uncoiling in place. It may also be beneficial to leave some of the packaging under the curtain to protect the finish during installation.
3. The coil will be provided with the top of the curtain on the outside, thus leaving the fastening sections exposed. Position the coil on the floor between the guides so that the open end of the fastening sections is facing up and nearer the wall.
4. Locate the curtain attachment hardware provided with the unit. Refer to the job information to ensure you have the correct type and quantity.

Figure 8.1 – Installing the Fastening Section

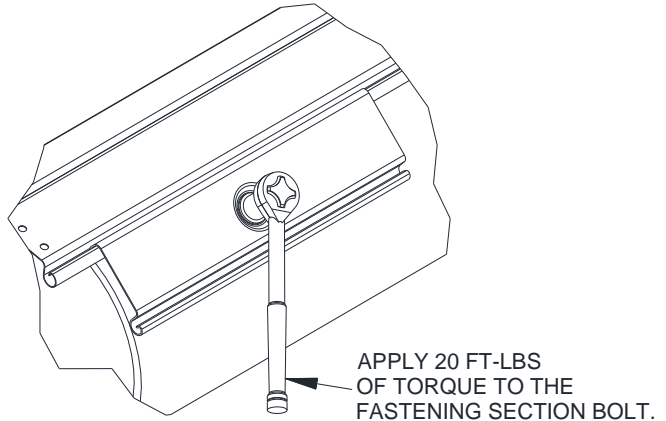

5. Lift the coil until it is just below the shaft. Using appropriately rated straps, sling the coil from the shaft as shown in **Figure 8.2**. Remove the plastic strapping securing the coil at this point.
6. Uncoil the curtain enough for the fastening sections to reach the attachment points on the shaft. Fasten them by aligning the fastening section with the hole in the shaft, and fasten using the provided hardware (See **Figure 8.1**). If the curtain is too heavy to uncoil by hand, use the method described in the following step to get the fastening sections in position.
7. Uncoiling a slung curtain using the operator:
 - For units with operators, use the hand chain override feature of the motor to rotate the shaft in the “open” direction. Be sure not to overrun the limits of the motor. The upper motor limit may have to be adjusted to reel the entire curtain onto the shaft.
8. Continue to rotate the shaft, reeling the curtain out of the sling and onto the shaft until the bottom bar reaches the bottom of the bracket.

Note: If you have not already installed the aluminum guide extrusions, install them now.

9. Feed the bottom bar through the UHMW bellmouths and into the guides. Lower the curtain until the bottom bar is below the stopper location.
10. Since there is no spring tension holding the curtain open, the curtain may fall if released. If the operator cannot be used to hold the curtain in the open position, place C-clamps or vice grips on the guides just below the bottom bar -or- rest the bottom bar on the slings used to hang the shaft in the previous steps to hold the door open.
11. Reposition the stoppers so that they protrude into the opening.

Figure 8.2 – Installing the Curtain

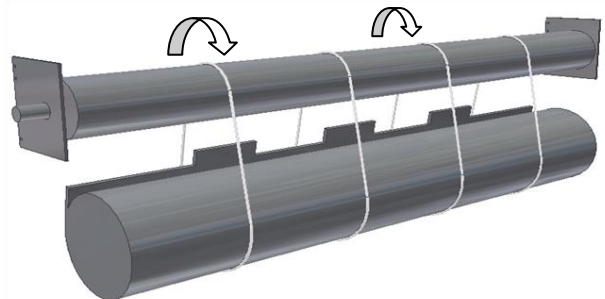

Note: If curtain shows signs of coning after attachment to the shaft, place provided shims on bottom bar end plug on the side that the curtain is coning towards. This will reduce the amount of coning of the curtain.

Section 9 – Sensor Mounting

▪ Sensor Mounting:

1. Locate all of the sensor mounting brackets, bottom bar flag, hardware, and wiring (pre-wired to the control panel).
2. Ensure that the proper photoeye and light curtain are placed on the proper side of the door. The photoeye transmitter (identified by “SMT” in the part number or the red housing) and the light curtain receiver (identified by “SGR” in the part number) will be placed on the “operator” side of the door. The photoeye receiver (identified by “SMR” in the part number of the yellow housing) and the light curtain transmitter (identified by the “SGT” in the part number) will be placed on the “adjustor” side of the door.
3. Attached the sensors to the lower mounting brackets as shown in **Figure 9.1**. Note that the brackets have been provided as a right hand and left hand configuration in order to provide the greatest amount of access possible during installation.

Figure 9.1 – Lower Sensor Mount

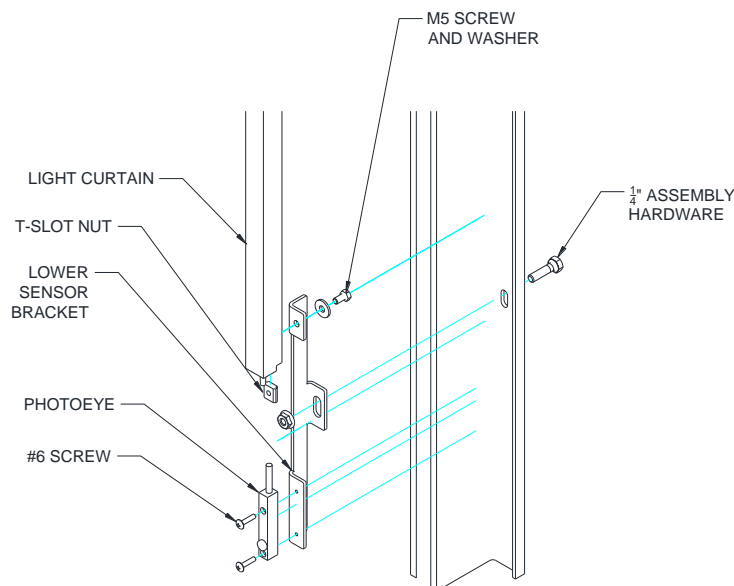

4. Once the lower mounting brackets are secure, determine the location of the upper light curtain bracket by either measuring from the bottom assembly fastener located at 10" above the floor to the upper assembly fastener as shown in **Figure 9.2** or holding the light curtain in place and marking the required bracket location.

Section 9 – Sensor Mounting

Figure 9.2 –Sensor Mount Locations

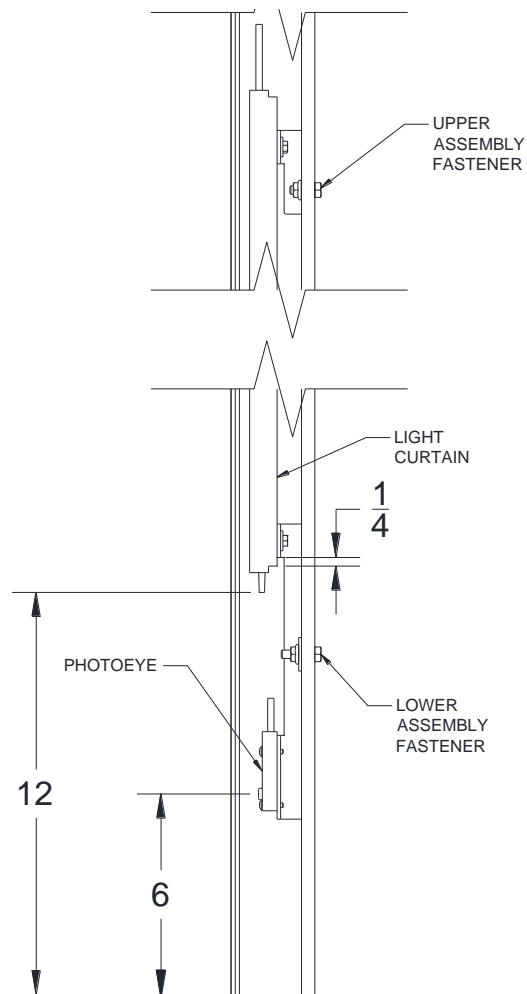

5. Remove the bottom assembly fastener and the selected upper assembly fastener and use to secure the sensors in place. If required, longer $\frac{1}{4}$ " bolts have been provided for the additional thickness of the mounting bracket.
6. Once the sensors are secured to the guide/wall angle, connect the sensors using the pre-wired plug and play cables (Short cable to "operator" side sensors and long cable to "adjustor" side sensors). Attach the plug and play Y connector to the guide using the adhesive mount provided as shown in **Figure 9.3**. It is important that the cables are run in a manner such that they will not interfere with sensors, using the provided cable management clips if needed.

Section 9 – Sensor Mounting

Figure 9.3 – Trim and Y Connector

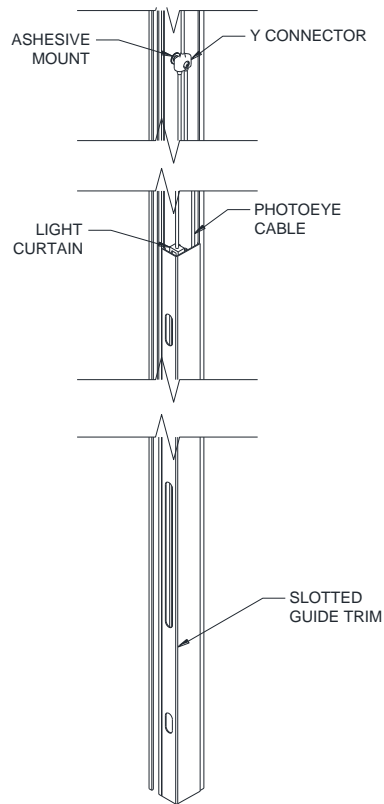

7. If power is available, it is recommended to check the alignment of the sensors at this time prior to installing the guide trim.
8. At this time, the guide trim can be installed using the slotted guide trim to cover the sensors and the solid guide trim installed directly on top of the slotted guide trim as shown in **Figure 9.3**. If a pitch plate is required, a second piece of solid guide trim is provided to be installed underneath the slotted guide trim on the lower side of the opening.

Section 9 – Sensor Mounting

9. If using an extruded tubular bottom bar, install the bottom bar flag as shown in **Figure 9.4** using the provided hardware.

Figure 9.4 –Bottom Bar Flag



If using a double angle bottom bar, loosen the bottom bar assembly fastener closest to the guide and insert the provided bottom bar flag as shown in **Figure 9.5**. Re-tighten the fastener at this time.

Figure 9.5 –Bottom Bar Flag

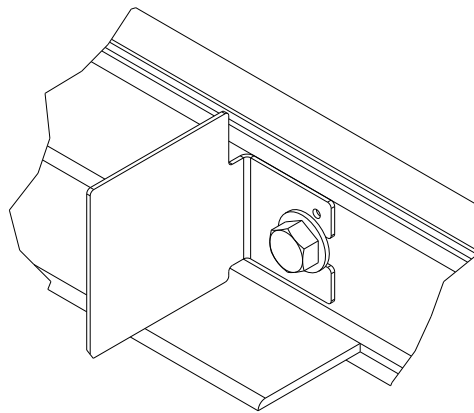

⚠WARNING

The bottom bar flag must be installed prior to commissioning the door. Failure to do so is likely to cause permanent damage to the door.

Section 10 – Hood, Fascia, and Covers

▪ Hood Support Installation:

1. Refer to the job information to determine the type and quantity of hood supports required for your door. Hood supports will be noted on the elevation view of the job construction drawings. See **Figure 10.1** for hood support types.

Figure 10.1 – Hood Supports

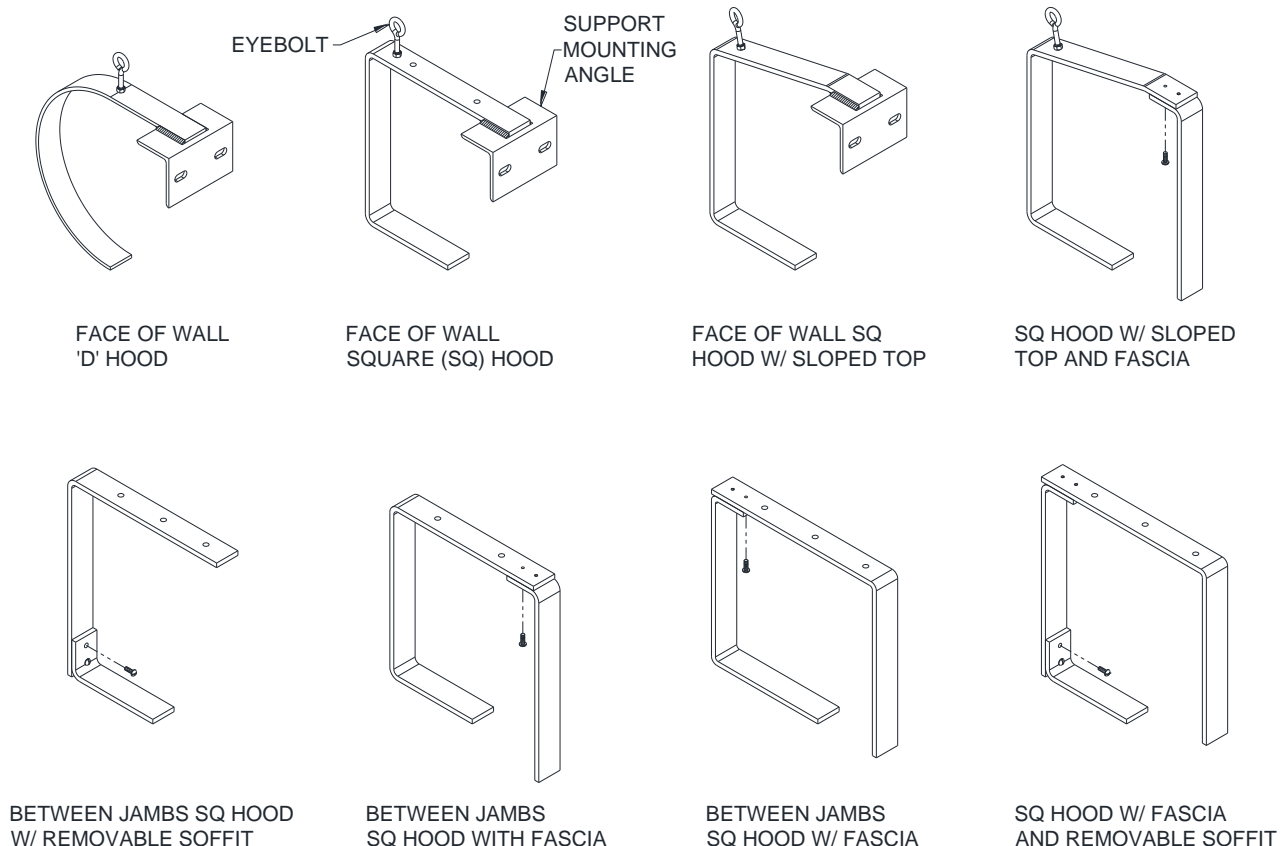

2. Determine where the support(s) will be located between the guides.
 - a. If multiple supports are required, see the job construction drawings to determine the centerline of each.
 - b. If a single support is required, it will be located at the center of the unit.
3. Mark a line on the lintel or ceiling (for units without a lintel) at the centerline of each support.
4. Check the construction at the support locations to be sure it is strong enough to handle the weight of the hood.

Note: If the construction is not strong enough, do not proceed until rectified.

5. The term “top of the coil” refers to the top edge of the brackets and hood which house the curtain (The curtain in the fully open position is referred to as the “coiled curtain”. The top of the coiled curtain is not actually located at the “top of the coil”, it is lower than the top of the coil) Locate the “top of the coil”:
 - a. This is typically at the top of the wall angle or intermediate angle.
 - b. If there is no wall or intermediate angle, see the job construction drawings for the distance from the bottom of the unit to the top of the coil.
 - c. If there is a ceiling at the top of the coil, skip the next step.
6. Mark a line at the top of the coil at both guides of the unit. Project the lines together to make a continuous line.
 - a. This will help locate the top of the hood support which will keep the hood level.
7. Project a line from the fascia mounting location (fascia mounting channel or fascia side of the tube) from one guide to the other.

Section 10 – Hood, Fascia, and Covers

8. Mark a line at the support centerline along the fascia line.
9. Prepare the location of the attachment point of the support(s) prior to installing the barrel. This will make installing the support much easier when the time comes to attach it to the lintel/header or ceiling.
 - a. Hold the support in place at the determined location and mark the mounting hole locations.
 - b. Drill holes in the construction.
10. Attach the hood support to the lintel/header or ceiling to be sure the mounting holes were located properly.
11. Remove the hood support and proceed to the **“Barrel and Brackets”** section.
12. Once the barrel, brackets, curtain are installed, and necessary testing was done on the unit, re-install the hood support.

▪ **Hood and Fascia Installation:**

1. Determine what type of hood was provided. This can be done by:
 - Looking for a ‘D’ hood strap or clip angles welded to the brackets.
 - Looking in the hood box and comparing to the job construction drawings.
2. If a square hood is provided, check the job construction drawings to see if it has multiple parts (such as a two sided hood with a removable soffit, two sided hood without a top piece, two sided hood with a sloped top, etc). See **Figure 10.2** for possible hood configurations.
3. Fasten the hood and fascia accordingly using the fasteners provided. Ensure hoods with multiple sections overlap correctly.
 - ‘D’ hoods end between the brackets.
 - Square hoods end flush with the outer edge of the brackets.
4. If there is a hood support:
 - ‘D’ hood sections overlap the centerline of the hood support by 1/2”.
 - Square hood sections do **not** overlap at the hood support. They butt against each other and a hood splice cover is provided to cover the joint, see **Figure 10.3**.

Note: *If there is a hood support, pre-drill holes in it to ease hood attachment. A #21 drill size is recommended.*

Section 10 – Hood, Fascia, and Covers

Figure 10.2 – Hood Configurations

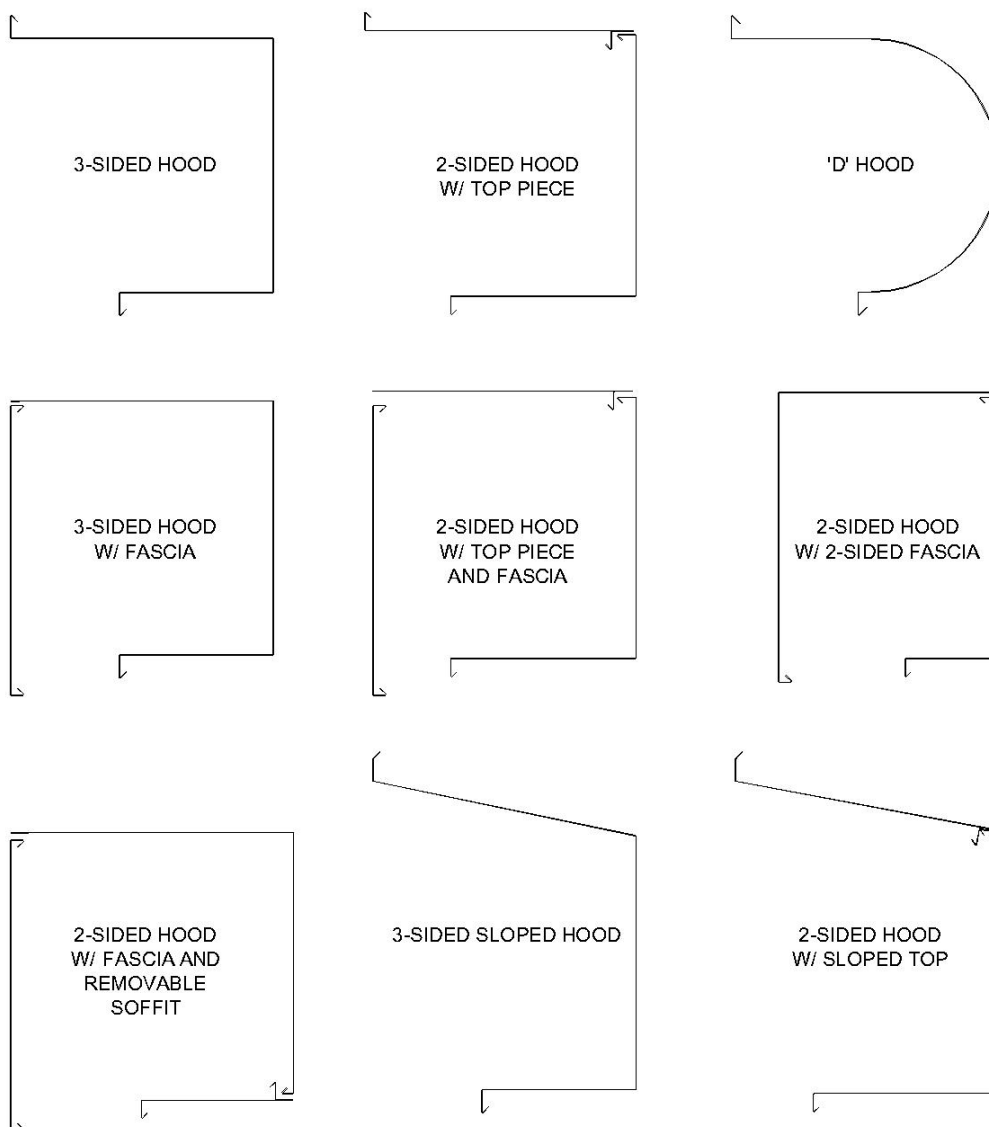

▪ **Hood Splice Cover:**

1. Hood splice covers are provided for square hoods only. Prior to installing the splice cover, operate the door a few times once you've installed the hood, to verify that the hood is not interfering with the door.
2. Install the splice cover at this time.
3. Slip the bottom return bead on the splice cover into the soffit return on the hood, and then attach the top of the splice cover with the fasteners provided.
4. If there is not return bead on the soffit of the hood, fasten the bottom of the splice cover to the soffit.

Section 10 – Hood, Fascia, and Covers

Figure 10.3 – Hood Splice

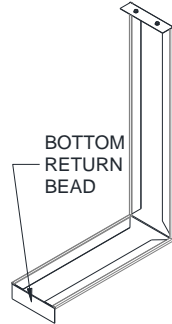
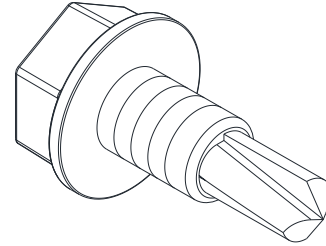

Figure 10.4 – Hood and Cover Screw (#10-16 x 1/2")



▪ **Cover Installation:**

1. Once the unit is installed and operating correctly, the covers can be installed.
2. Hood screws may have to be removed and reinstalled to install covers properly.
3. If the cover mounts to the side of the door bracket, pre-drill holes in the bracket to ease installation. A #21 drill size is recommended.
4. If an operator or idler cover is provided, individual installation instructions are provided with each cover along with the necessary hardware to attach the cover.
5. Once the cover is installed, operate the door a few more times to be sure there is no interference between the moving components inside the cover and the cover itself.
6. If the door is mounted on the exterior of the building, a bead of silicone sealant should be applied around the entire perimeter of the cover, as it will provide additional protection to the door components.

Section 11 – Maintenance Schedule

Table 11.1 – Torque Recommendations for Guide Assembly and Wall Fasteners

Bolt size/type	Torque (ft lbs) ^a
1/4-20 Grade 2 steel bolt	6
5/16-18 Black Oxide Socket Cap	25
3/8-16 18-8 stainless steel bolt	20
3/8-16 Grade 2 steel bolt	20
3/8-16 Grade 5 steel bolt	31
1/2-13 Grade 5 steel bolt	75
1/2-13 Grade 8 steel bolt	107
5/8-11 Grade 8 steel bolt	212
3/4-10 Grade 8 steel bolt	376
^a The recommended torque for steel bolts is based on a plated bolt that has not been lubricated.	

Table 11.2 - Torque Recommendations for Solid Masonry Wall Anchors

Anchor Size (nominal)	Manufacturer/Torque (ft lbs) ^a	
	Simpson Wedge-All	Hilti-Kwik Bolt 3
3/8	30	20
1/2	60	40
5/8	90	85
3/4	150	150
^a Torque values for grout filled block are different, reference bolt manufacturer for these values.		

Section 12 – Maintenance Schedule

▪ **Maintenance Schedule:**

Note: If any of the following problems exist, **do not** operate the door until repaired.

Component	What to look for and how often the components must be inspected:	Weekly	Monthly	Quarterly	What to do if problem exists:
Curtain & Bottom Bar	Are any curtain components damaged (slats, endlocks, etc.)?	X			Contact Service about replacing damaged parts.
	Is bottom bar damaged?	X			Contact Service about replacing damaged parts.
	Are bottom bar fasteners in place and properly tightened?		X		Fasteners must be inspected/replaced and properly tightened.
	Are fasteners attaching curtain to the barrel in place and properly tightened?		X		Fasteners must be inspected/replaced and properly tightened.
	Do you notice any hang-ups, jamming or other problems preventing the door from moving smoothly throughout the opening?	X			Check for external issues, if none exist, contact Service.
	Do you notice any odd or excessive noise when the door is operated?	X			Check for external issues, if none exist, contact Service.
	If there is a bottom seal, is it damaged?		X		Contact Service about replacing damaged parts.
	If there is locking, does it function properly?	X			Check for external issues, if none exist, contact Service.
Brackets	Are brackets plumb and perpendicular with wall?			X	Contact Service.
	Are bracket fasteners in place and properly tightened?			X	Fasteners must be inspected/replaced and properly tightened.
	Do you notice signs of excessive wear on the bearings (i.e. binding, excessive noise, etc.)?		X		If there is a grease fitting, apply grease, if not, contact Service.
	Is adjusting wheel & pin secure?			X	Contact Service.
	Is drive chain sufficiently lubricated?			X	Apply chain lube.
	Is drive chain in need of tightening?			X	Contact Service for instructions on how to tension the chain.
	Is drive or driven sprocket damaged?		X		Contact Service about replacing damaged parts.
Guides	Are wall fasteners in place and properly tightened?		X		Fasteners must be inspected/replaced and properly tightened.
	Are guide assembly fasteners in place and properly tightened?		X		Fasteners must be inspected/replaced and properly tightened.
	Is guide gap dimension correct?		X		Check job construction drawings and adjust gap as required. If job construction drawings are not available, contact Service.
	Are any of the guide parts bent or damaged?		X		Contact Service.
	Are stoppers loose, damaged, or missing?		X		Stoppers must be inspected/replaced and properly tightened.
Hood and Fascia	Is hood/fascia dented or damaged?			X	Remove hood/fascia. Repair if possible. If not leave hood/fascia off and contact Service.
	Is curtain rubbing against the hood/fascia?	X			Hood/fascia may have been damaged. Contact Service.
	Is hood/fascia level?			X	Check fasteners, they may be loose or missing. Replace as soon as possible.
	Are guide assembly fasteners in place and properly tightened?		X		Fasteners must be inspected/replaced and properly tightened.

Section 12 – Maintenance Schedule

	Is hood support level?			X	Check fasteners, they may be loose or missing. Replace as soon as possible.
Door operation	Does the door require excessive force to open?		X		Check for hang-ups or obstructions. Ensure spring tension is set correctly. Contact Service.
	If the door contains locking, does the locking mechanism function properly and securely hold the door in the closed position?		X		Check for damage and other external issues. Contact Service.
	If there is a sensing edge, does it function properly?	X			Cut power and check for loose wires. Contact Service for further instruction.
	Does the light curtain function properly?	X			Cut power and check for loose wires. Contact Service for further instruction.
	If there are photoeyes, are they functioning properly?	X			Cut power and check for loose wires. Contact Service for further instruction.
Motor Operator	Are the fasteners attaching the motor-to-the mounting bracket, and mounting bracket-to-the door bracket secure?			X	Fasteners must be inspected/replaced and properly tightened. Contact Service for replacement hardware.
	Are the sprockets properly aligned?			X	Realign the sprockets as secure using the set screws. Recheck chain tension.
	Are the sprocket keys properly aligned with sprockets and securely fastened with the set screws?			X	Reposition the keys so they fully engage the keyway in the sprocket. Tighten the set screws.
	Is the door stopping correctly at the open (before bottom bar contacts the stoppers) and closed (as soon as the bottom bar contacts the floor) positions?		X		Limits may have to be adjusted in the motor operator. Refer to the operator owner's manual or contact Service.
	Is the operator functioning normally?		X		Refer to the <i>Operator Troubleshooting Table</i> on the following page to diagnose the problem.
	Does the drive chain have sufficient tension?		X		Shims may have to be used to space out motor operator or a link may have to be removed from drive chain.
Inertia Brake	Is the red tab pushed out of the housing?	X			Contact Service.
	Is the safety brake making any unusual noise or vibrating while the door is operating?	X			Contact Service.

Section 12 – Maintenance Schedule

▪ **Operator Troubleshooting:**

Note: If you suspect you are having an issue with your operator, use the following table to determine the potential causes. If the provided solution does not eliminate the issue, or the table does not address your particular problem, contact the Service Department.

Component	Problem	Potential Cause	Solution
Motor Operator	Motor Operator does not run when OPEN or CLOSE button is pushed	The circuit breaker may be flipped or fuse blown.	Reset breaker or replace fuse. Contact Service if replacement fuse is needed.
		The thermal overload may be tripped.	Reset thermal overload.
		Manual interlock switch is open (on units with emergency operator).	Close manual interlocks.
		External interlock may be opened.	Close external interlock.
	Motor operator runs but the door does not move	Sprocket key may be missing or drive chain may be broken.	Contact Service for repair parts. Install key or replace chain.
		Clutch may be slipping.	Adjust if possible. Contact Service otherwise.
	Motor hums but does not run	Door or drive chain may be jamming.	Check for hang-ups or obstructions. Try to operate manually. If issue persists, contact Service.
		Dead phase in 3 phase system.	Check power supply.
		Brake does not release.	Check power to brake solenoid.
		Open motor winding.	Check that all connections are secure.
	Motor operator runs in wrong direction and limits do not function	3 phase operator power supply is out of phase.	Interchange any 2 power leads to unit.
	Door drifts when motor shuts off	Brake may be improperly adjusted or broken.	Check brake components. Contact Service for replacement parts or adjust instructions.
	Motor operator does not shut off at full OPEN or at full CLOSE position	Limits may need adjustment.	Refer to the operator owner's manual to readjust limits.
		Sprocket on limit shaft may be slipping or limit drive chain may be broken.	Ensure sprocket key is correctly installed and set screws are tightened. Contact Service for replacement chain if broken.
Limit switch may be defective.		Contact Service.	
Limit Switches	Limit switch does not hold setting	Drive chain may be too loose, allowing the chain to jump sprocket teeth.	Adjust chain to proper tension. Contact Service for additional information.
		Limit nut retainer not engaging slots in limit nuts.	Be sure retainer is securely engaged in slots of both limit nuts.
		Limit nuts binding on screw threads, allowing them to jump position on retainer.	Lube screw thread. Check that limit nuts turn freely.

Appendix A – Extreme® 300 Series Construction and Maintenance

- **Extreme® 300 Series Construction:**
- **Special Notes:**
 1. The basic assembly sequence is as follows: guides, springless barrel w/ tapped holes, brackets (pre-assembled with bellmouths and inertia brake (if required)), motor operator, curtain, stoppers, weather stripping, hood, and operator/idler covers.
 2. Prior to installing brackets onto the shaft, install the provided spacers onto the shaft.
 3. Inertia brakes (if required) must be wired into operator interlock in case of failure.

Warranty Statement

Cornell Iron Works warrants to the buyer that the 300 Series grille will be free of defects in material and workmanship (ordinary wear and tear expected) for the time periods set forth below:

- **Mechanical** components for a period of **Two Years or 300,000 cycles**, whichever comes first, from the date of shipment.
- **Operator and Control panel** for a period of **Two Years or 300,000 cycles**, whichever comes first, from the date of Shipment.

This warranty does not include extra materials, equipment or labor that may be required due to site conditions, adjacent construction, incorrect installation, lack of maintenance, lack of access, ordinary wear, abuse or neglect. Documentation of a properly executed maintenance program will be required prior to corrective action being authorized. The design of coiling products by nature will abrade virtually any applied finish. For this reason, Cornell Iron Works does not warrant either standard or optional finishes. Component wear is to be expected in the normal operation of a high cycle door. Cornell agrees to repair or replace, at Cornell's discretion, any parts which are determined, by Cornell, to be defective.

Job specific warranties, or warranties with obligations in addition to those listed above must be stated in writing and signed by Cornell.

PREVENTATIVE MAINTENANCE AND TEST PROCEDURES

These grilles have been designed for a minimum of maintenance. All scheduled maintenance and test procedures are to be found in this section.

Maintenance Schedule					
Cycles/Time (Whichever Occurs First)					
	75,000/ 6 Months	150,000/ 12 Months	225,000/ 18 Months	300,000/ 24 Months	375,000/ 30 Months
Visual Inspection	INSPECT	INSPECT	INSPECT	INSPECT	INSPECT
Bracket Bearings	INSPECT	<u>LUBRICATE</u>	INSPECT	<u>LUBRICATE</u>	INSPECT
Drive Chain (if Required)	INSPECT	<u>LUBRICATE</u>	INSPECT	<u>LUBRICATE</u>	INSPECT
Limit Nuts/Shaft (If Required)	INSPECT	<u>LUBRICATE</u>	INSPECT	<u>LUBRICATE</u>	INSPECT
Motor Operator	INSPECT	INSPECT	INSPECT	INSPECT	INSPECT
Operator Brake Operation	TEST	TEST	TEST	TEST	TEST
Inertia Brake (If Required)	INSPECT	INSPECT	INSPECT	INSPECT	INSPECT
Sensing Edge (If Equipped)	TEST	TEST	TEST	TEST	TEST
Photoeyes/Light Curtain	TEST	TEST	TEST	TEST	TEST
Bellmouths	INSPECT	INSPECT	INSPECT	INSPECT	INSPECT
Guide Wear Strip	INSPECT	INSPECT	INSPECT	INSPECT	INSPECT
Maintenance Date					
Cycle Counter Readout					
Service Initials					

Appendix A – Extreme® 300 Series Construction and Maintenance

Comprehensive Maintenance

<u>Item</u>	<u>Check</u>
Visual Check	Visually inspect grille for unreported damage. Repair or replace any damaged parts. Visual inspection includes curtain, guides, hoods, and control panel.
Operational Check	Operate grille one full cycle while inspecting grille operation for binding, straining, or unusual noises. Correct any operational problems found.
Motor Check	Operate grille one full cycle while checking motor for unusual noises, smells, or smoke. Correct any motor operational problems found.
Drive Chain Lubrication/Inspection	Inspect roller chains, sprockets, and gears. Replace any sprockets or gears with teeth worn where they do not operate smoothly. Lubricate chains and gears with SAE approved gear oil. Adjust chain tension as required. Replace chain if stretched to point where it makes noise.
Safety Brake Inspection	Verify that red tab is not pushed out of housing. Operate grille one full cycle while checking for unusual noises and vibration. If red tab is pushed out or if unusual noises or vibrations are witnessed, Contact Service.
Limit Shaft/Nuts	Verify the threads on the limit shaft are not worn and are lubricated properly. Check for excessive shaft end play. Verify the limit nuts do not wobble excessively or bind on the limit shaft. Use SAE approved gear oil for lubrication.
Operator Inspection	Operate grille in the close direction and hit the “Stop” button when the bottom bar is about 36” above the finished floor. Verify that the brake does not allow the grille to continue to move in the closed direction more that 2” after the initial brake engagement.
Bracket Bearings	Inspect the bracket bearings for worn outer races and debris. Lubricate the bearings with bearing grease via the supplied grease fittings.
Sensing Edge	Operate the grille in the closing direction and contact the edge to verify edge functions and grille returns to the fully open position. Check the battery condition in the transmitter and replace battery if required. Inspect the bottom surfaces of the edge for cracking or separation at ends.
Photo-Eyes/Light Curtains	Operate the grille in the closing direction and place an obstruction in the path of the photo-eyes as the grille is in mid-travel. Verify that the grille stops and reverses to the fully open position.